



WR-531-280

Technical Data Sheet

Waste Receptacle Free Standing – Thirteen Gallons



Front View

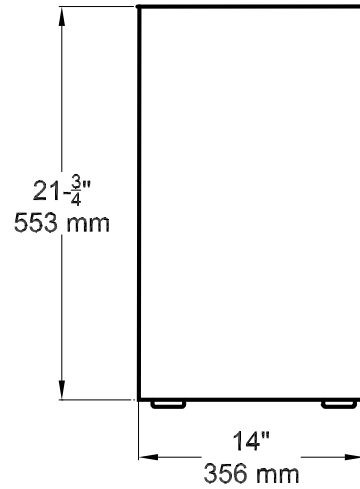

Side View

MATERIALS: The unit is fabricated of 22 gauge stainless steel, No. 4 satin-finish

SPECIFICATIONS: Free Standing Waste Receptacle with Open Top. Unit is fabricated of 22 gauge stainless steel with a satin-finish. Unit is equipped with a vinyl wall bumper and rubber feet. All corners are radiused. Thirteen gallon (49 L) capacity.

CAPACITY: 13 Gallons (49 L)

OVERALL SIZE: 14" W x 14" sq. x 21 3/4" H
(356 mm W x 356 mm sq. x 553 mm H).

INSTALLATION: Waste receptacles can be placed in area that will not interfere or obstruct passage areas. Units can be easily serviced by emptying contents from unit.

The manufacturer reserves the right, without formal notification, to implement changes to the design and dimensions.
© 2008 Columbia Accessories
Edition: WR-531-280/001



PO Box 181, Columbia, SC 29202
Phone: 1-866-820-3579 Fax: 1-866-317-2786
Web Site: <http://www.natpart.com>