

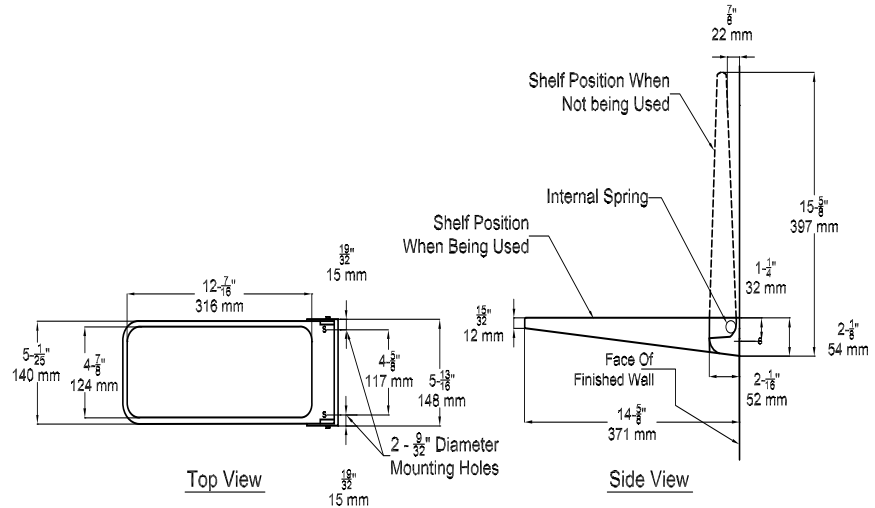

US-401-200

Technical Data Sheet

Folding Utility Shelf Surface Mounted



MATERIALS: Shelf: 18-8, type 304, No.18 gauge stainless steel. Bracket: 18-8, type 304, No.14 gauge stainless steel.

OVERALL SIZE: 5 1/25" W x 15/32" – 2 1/16" H x 14 5/8" D
 (140 mm W x 12 mm H – 52 mm H x 371 mm D)

SPECIFICATIONS: Folding Utility Shelf will have self-contained mounting bracket and will be fabricated of seamless alloy 18-8 stainless steel, type 304, No.18 gauge. Top surface of shelf will have raised rim to prevent objects from slipping off shelf. All exposed surfaces will be No.4 satin finish and be protected during shipment with a PVC film that removes easily after installation. Structural reinforcement will be of welded construction. All exposed edges and corners will have radius and burr free. Internal spring counterbalance will be captive and suitable for heavy-duty service. Shelf will automatically return to vertical storage position when not in use.

INSTALLATION: Unit is surface mounted. Secure unit to wall or toilet partition with hardware supplied by installer to match installation type. Ensure mounting configuration complies with local building codes.

The manufacturer reserves the right, without formal notification, to implement changes to the design and dimensions.
 © 2008 Columbia Accessories
 Edition: US-401-200/001



PO Box 181, Columbia, SC 29202
 Phone: 1-866-820-3579 Fax: 1-866-317-2786
 Web Site: <http://www.natpart.com>