

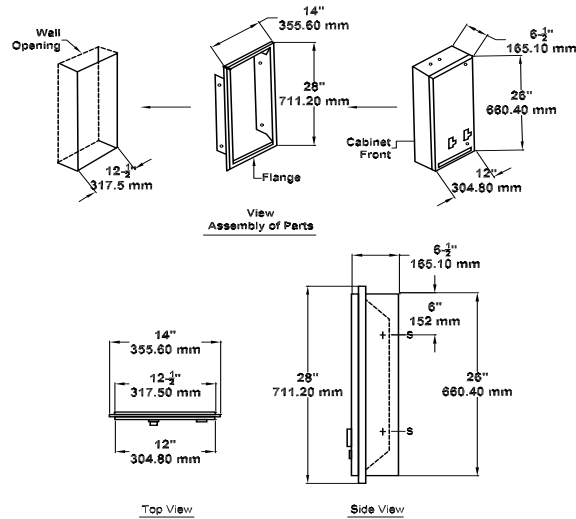

NV-111-200

Technical Data Sheet

Napkin and Tampon Vendor



MATERIALS: The unit is fabricated of type 304 stainless steel, No. 4 satin finish.

SPECIFICATIONS: The body of the unit is fabricated of type 304 stainless steel, No. 4 satin finish. The door is fabricated of type 304 #18 gauge stainless steel, and is secured with a continuous stainless steel piano hinge. The frame is fabricated of type 304 #18-8 gauge stainless steel with a #4 satin finish. The adjustable frame is provided with 1/4" (6 mm) return for rigidity. The coin mechanisms can be changed without removing unit from wall. Two independent, trouble free turn knob mechanisms, with an "EMPTY" indicator that does not allow coins to be inserted into mechanism when product has been depleted. Operational with one hand with less than 5 lbs (22.2n) of force without tight grasping. Coin box is fitted with tumbler lock keyed differently from the door for added security. The adjustable flange allows for full recess, semi-recess or surface mounting. (Flange is 14" W x 28" H or 356 mm x 711 mm).

CAPACITY: Napkins: 30, Tampons: 27

OVERALL SIZE: 14" W x 28" H x 6 1/2" D
(356 mm W x 711 mm H x 165 mm D)

WALL OPENING: 12 1/2" W x 26 1/2" H x 2" min – 6 1/2"max. D
(318 mm W x 673 mm H x 51 mm-165 mm D)



When mounted properly, unit will comply with ADA Code 4.27.4 ADA mounting requirement is 61 1/2" (1562 mm) from finished floor to top of unit.

INSTALLATION: Provide framed wall opening 12 1/2" W x 26 1/2" H x 2" min – 6 1/2"max. (318 mm x 673 mm x 51 mm-165 mm). Flange is to be placed inside wall opening and secured to rough wall framing with (4) #10 flat head screws. Insert unit into flange and adjust to required depth. Unlock the door and then secure cabinet to framing with (4) #10 pan head screws located at the top and bottom of the unit. Screws are not provided by manufacturer.

The manufacturer reserves the right, without formal notification, to implement changes to the design and dimensions.
© 2008 Columbia Accessories
Edition: NV-111-200/001



PO Box 181, Columbia, SC 29202
Phone: 1-866-820-3579 Fax: 1-866-317-2786
Web Site: <http://www.natpart.com>