

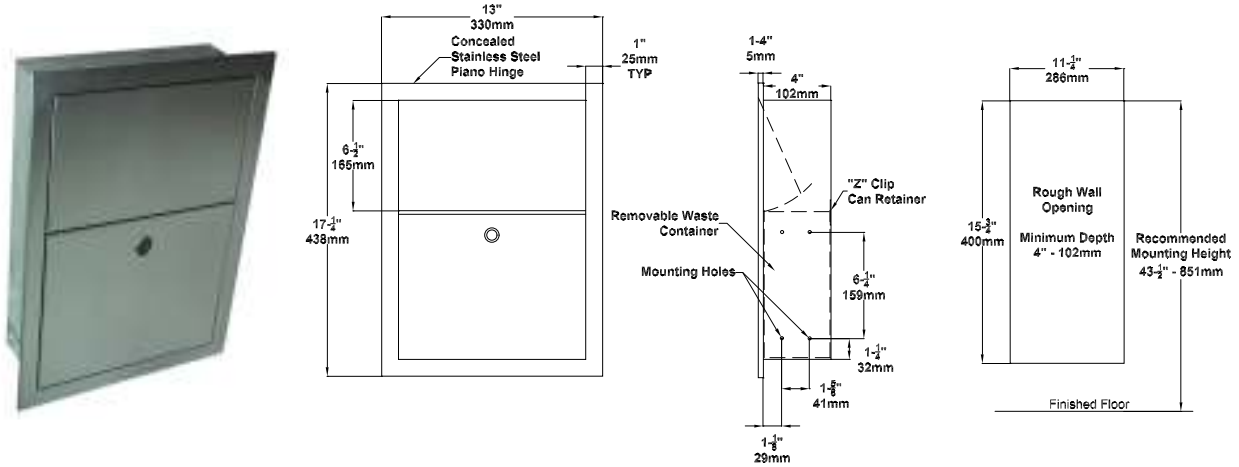

**ND-321-200**

**Technical Data Sheet**

**Sanitary Napkin Disposal  
Recessed (End Stall Unit)**



**MATERIALS:** The unit fabricated of 18 and 22 gauge 18-8 type 304 stainless steel with No. 4 satin finish.

**SPECIFICATIONS:** The unit is fabricated of alloy 18-8 stainless steel, type 304, 22 gauge, No. 4 satin finish and is all welded construction. The door opens by user pushing on door facing and is self closing. The self-closing push door is mounted with full length concealed stainless steel piano hinge. Stainless steel inner container is removable for servicing and is emptied by removing waste/trash bag from can.

**CAPACITY:** 1.5 gal (5.7 liters)

**OVERALL SIZE:** 13" W x 17 1/4" H x 4" D  
(330 mm W x 438 mm H x 102 mm D)

**WALL OPENING:** 11 1/2" W x 16 1/4" H x 4" D  
(292 mm W x 413 mm H x 102 mm D)

**INSTALLATION:** Provide wall opening 11 1/2" W x 16 1/4" H x 4" D (292 mm x 413 mm x 102 mm). The unit is to be mounted in rough wall framing using # 10 self tapping screws through concealed mounting holes provided. The top of rough wall opening is 3/4" below top of unit. Screws are not provided by manufacturer.



Per the ADA, the suggested mounting is 28" (711 mm) above finished floor to top of unit. Hinged panels covering waste receptacle openings should not require more than 5 lbs. of force to open.

The manufacturer reserves the right, without formal notification, to implement changes to the design and dimensions.  
© 2008 Columbia Accessories  
Edition: ND-321-200/001



PO Box 181, Columbia, SC 29202  
Phone: 1-866-820-3579 Fax: 1-866-317-2786  
Web Site: <http://www.natpart.com>