

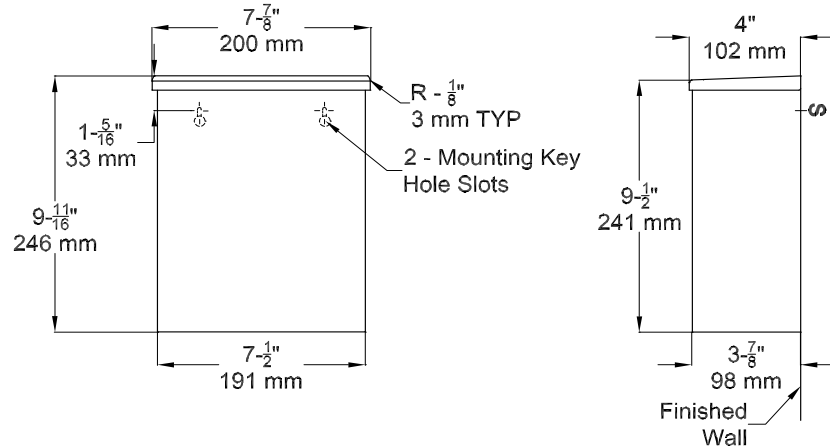

# ND-111-200

## Technical Data Sheet

### Sanitary Napkin Disposal Surface Mounted



**MATERIALS:** The unit is fabricated of alloy 18-8 stainless steel, type 304, 22 gauge, No. 4 satin finish.

**SPECIFICATIONS:** The cabinet and door of unit are fabricated of alloy 18-8 stainless steel, type 304, 22 gauge. All exposed surfaces are No. 4 satin finish and are protected with a PVC film that is removable after installation. Top cover is attached to cabinet with a full length  $\frac{3}{16}$ " diameter stainless steel multi-staked piano hinge. Structural assembly of body and door components is welded construction.

**OVERALL SIZE:**  $7\frac{7}{8}$ " W x  $9\frac{11}{16}$ " H x 4" D  
(200 mm W x 246 mm H x 102 mm D)

**OPERATION:** Top of unit lifts. User lifts top and deposits waste material into unit. Unit is emptied by lifting lid and removing waste/trash bag from unit.

**INSTALLATION:** Unit is surface mounted on wall or partition No 10 self tapping screws (by others). Two (2) mounting holes through back are "keyhole" slots for ease in hanging unit on pre-installed screws. For compliance with ADA Accessibility Guidelines, unit should be installed so that top cover is 30" (762mm) above finished floor.

The manufacturer reserves the right, without formal notification, to implement changes to the design and dimensions.  
© 2008 Columbia Accessories  
Edition: ND-111-200/001



PO Box 181, Columbia, SC 29202  
Phone: 1-866-820-3579 Fax: 1-866-317-2786  
Web Site: <http://www.natpart.com>