

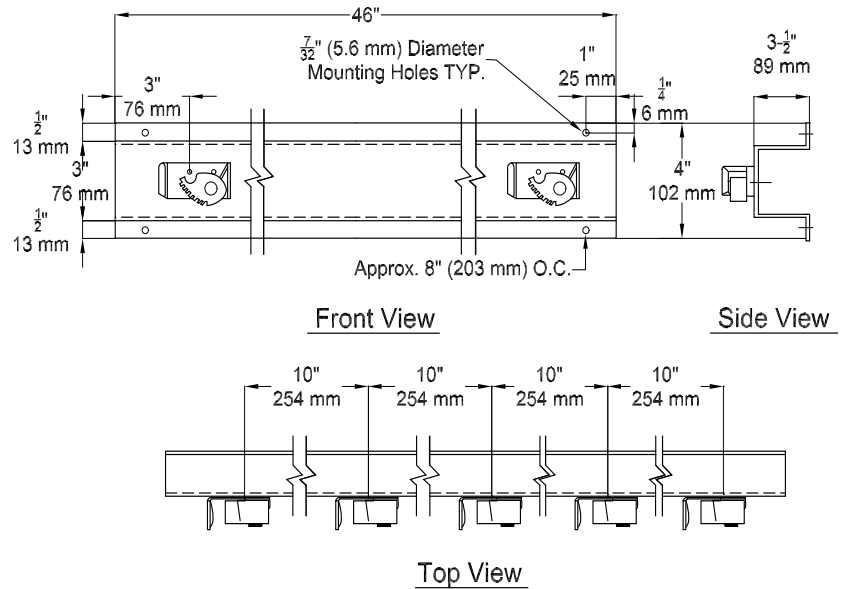

# MS-131-200

## Technical Data Sheet

### Mop And Broom Holder Rack Surface Mounted - 46" 5 Mop Holders, 4 Rag Hooks



**MATERIALS:** Rack is fabricated of one piece alloy 18-8 stainless steel, type 304, 20 gauge (.9 mm) with No. 4 satin finish.

**OVERALL SIZE:** 46" W x 4" H x 3 1/2" D  
(1168 mm W x 102 mm H x 89 mm D)

**SPECIFICATIONS:** Mop and Broom Holder Rack will be fabricated of one-piece hi-hat channel alloy 18-8 stainless steel, type 304, 20 gauge (.9 mm) with No. 4 satin finish. Horizontal edges of hi-hat will return 3 1/2" (89mm) to wall. Mop holder brackets will be fabricated of cadmium-plated steel and will be ribbed for rigidity. Each mop holder shall have a pivoting spring loaded serrated rubber cam that shall hold round handles of 7/8" to 1 1/4" (22 mm to 32 mm) diameter wedged against ribbed clamp plate.

**INSTALLATION:** For general utility mount rack 70" (1778 mm) above finished floor from bottom of rack with No 10 self-tapping screws through holes provided. Screws are not provided by manufacturer.



**ADA Accessibility Guidelines:** For compliance with ADA Accessibility Guidelines, install unit so that top of rack is 54" (1372 mm) above finished floor if clear floor side reach access is provided or 48" (1219 mm) above finished floor if clear floor forward reach access is provided.

The manufacturer reserves the right, without formal notification, to implement changes to the design and dimensions.  
© 2008 Columbia Accessories  
Edition: MS-131-200/001



PO Box 181, Columbia, SC 29202  
Phone: 1-866-820-3579 Fax: 1-866-317-2786  
Web Site: <http://www.natpart.com>