

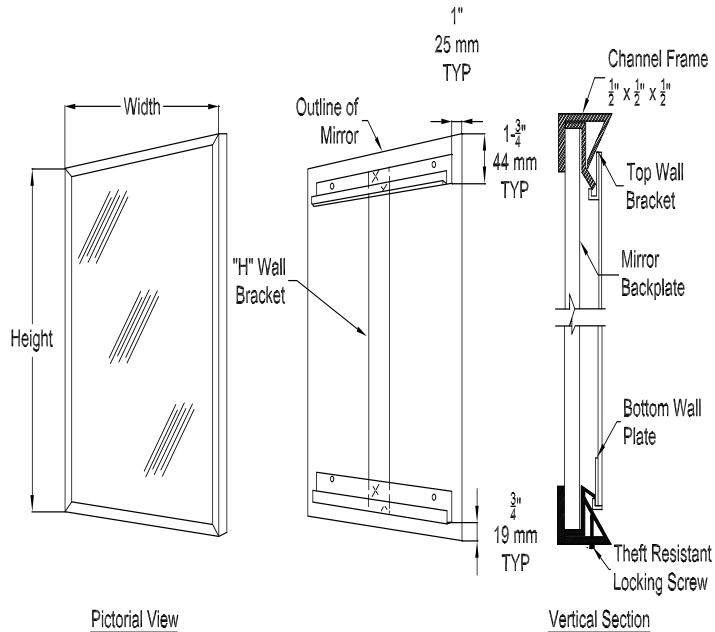

MR- 3 1 -200  
 Style Meas. Finish

**Technical Data Sheet**

**Channel Frame Mirror**



Style	Measurement	Finish
3 = Channel	1 = 16" x 24"	1 = SS # 304 Satin
	2 = 18" x 24"	
	3 = 18" x 30"	
	4 = 18" x 36"	
	5 = 24" x 36"	
	6 = 36" x 72"	
	7 = 42" x 36"	
	8 = 48" x 36"	
	9 = 16" x 30"	
	0 = 24" x 30"	



**MATERIALS:** The channel frame mirror is fabricated of alloy 18-8 Stainless Steel, type 304, 20 gauge, with No. 4 satin finish.

**SPECIFICATIONS:** The frame is fabricated of alloy 18-8 Stainless Steel, type 304, 20 gauge, with No. 4 satin finish. The frame is one piece construction with mitered corners and edges are burr free. The glass has standard glazing and is 1/4" thick plated with a 15 year warranty against silver spoilage. The mirrors meet Federal Spec. DD-M-411C. ASTM C-1036-91. All edges are protected by friction and chafe absorbing fillers. The back of mirror is protected by full shock-absorbing water-resistant filler and full size one piece 20 gauge corrosion protected steel. The top and bottom wall mounting brackets will be spot welded into "H" hanger. The mirror will be secured to lower bracket with a locking screw. Finish of unit will be protected from marring by removable self adhesive PVC film. Mirrors larger than 21sq.Ft. are fabricated in two or more sections to provide installation and handling ease.

**INSTALLATION:** Install "H" wall brackets level and plumb per diagram location using only #10 pan head screws. Hang mirror on brackets and tighten locking screw at bottom (this screw should be started before hanging mirror on wall brackets). Screws are not provided by manufacturer.



The ADA requires that the bottom of reflecting surface is to be installed 40" maximum above finished floor.

The manufacturer reserves the right, without formal notification, to implement changes to the design and dimensions.  
 © 2008 Columbia Accessories  
 Edition: MR- 3 \_ 1 -200/001



PO Box 181, Columbia, SC 29202  
 Phone: 1-866-820-3579 Fax: 1-866-317-2786  
 Web Site: <http://www.natpart.com>